

**DOT PRINTER
SP712 / 742 SERIES**

Hardware Manual

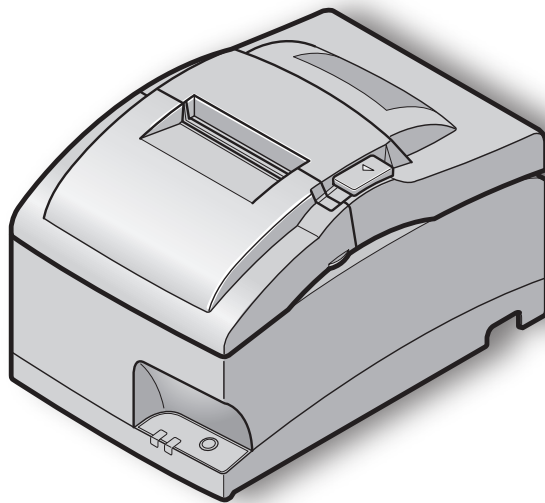

star 

Caution Symbol



This symbol is placed near the print head to indicate that it may be hot. Never touch the print head immediately after the printer has been used. Let the print head cool for a few minutes before touching it.



This symbol is placed near the cutter (auto cutter or manual cutter tear bar). Never touch the cutter blade, as you could injure your fingers.



This symbol label or stamp is placed near the screws securing the case, which should not be opened by individuals other than service personnel. Individuals, other than service personnel, should not remove these screws.



High voltage areas in the case can be dangerous.
This symbol is placed near the peripheral drive connector.
Do not connect this to a telephone.

Federal Communications Commission Radio Frequency Interference Statement

This device complies with Part 15 of the FCC Rules. Operation is subject to the following two conditions: (1) This device may not cause harmful interference, and (2) this device must accept any interference received, including interference that may cause undesired operation.

NOTE: This equipment has been tested and found to comply with the limits for a Class A digital device, pursuant to Part 15 of the FCC Rules. These limits are designed to provide reasonable protection against harmful interference when the equipment is operated in a commercial environment. This equipment generates, uses and can radiate radio frequency energy and, if not installed and used in accordance with the instruction manual, may cause harmful interference to radio communications. Operation of this equipment in a residential area is likely to cause harmful interference in which case the user will be required to correct the interference at his own expense.

This statement will be applied only for the printers marketed in U.S.A.

FCC WARNING

Changes or modifications not expressly approved by the party responsible for compliance could void the user's authority to operate the equipment.

For compliance with the Federal Noise Interference Standard, this equipment requires a shielded cable.

For RF interference suppression, if a ferrite core is provided with this device, affix it to the interface cable

Statement of The Canadian Department of Communications Radio Interference Regulationst

This Class A digital apparatus complies with Canadian ICES-003.

Cet appareil numérique de la classe A est conforme à la norme NMB-003 du Canada.

The above statement applies only to printers marketed in Canada.

< For Bluetooth models >

**Federal Communications Commission
Radio Frequency Interference
Statement**

This device complies with Part 15 of the FCC Rules and RSS-Gen of IC Rules. Operation is subject to the following two conditions:

- (1) this device may not cause harmful interference, and
- (2) this device must accept any interference received, including interference that may cause undesired operation.

This equipment complies with FCC/IC radiation exposure limits set forth for an uncontrolled environment and meets the FCC radio frequency (RF) Exposure Guidelines in Supplement C to OET65 and RSS-102 of the IC radio frequency (RF) Exposure rules. This equipment has very low levels of RF energy that it deemed to comply without maximum permissive exposure evaluation (MPE). But it is desirable that it should be installed and operated keeping the radiator at least 20cm or more away from person's body (excluding extremities: hands, wrists, feet and ankles).

This statement will be applied only for the printers marketed in U.S.A and Canada.

CE MARKING WARNING

Hereby, Star Micronics Co., Ltd. declares that this device is in compliance with the essential requirements and other relevant provisions of Directive 1999/5/EC.

Notice) This device can be operated in all European countries.

Italy: The public use is subject to general authorisation by the respective service provider.

Norway: This subsection does not apply for the geographical area within a radius of 20 km from the centre of Ny-Alesund.

This statement will be applied only for the printers marketed in Europe.

Trademark acknowledgments

SP700 : Star Micronics Co., Ltd.

Notice

- All rights reserved. Reproduction of any part of this manual in any form whatsoever, without STAR's express permission is forbidden.
- The contents of this manual are subject to change without notice.
- All efforts have been made to ensure the accuracy of the contents of this manual at the time of going to press. However, should any errors be detected, STAR would greatly appreciate being informed of them.
- The above notwithstanding, STAR can assume no responsibility for any errors in this manual.

TABLE OF CONTENTS

1. Unpacking and Installation	1
1-1. Unpacking	1
1-2. Notes about Installation.....	1
1-3. Handling Care	2
1-4. Maintenance.....	2
2. Parts Identification and Nomenclature	3
3. Setup.....	4
3-1. Connecting the Cable to the PC.....	4
3-2. Connecting the Cable to the Printer.....	5
3-3. Connecting to a Peripheral Unit.....	8
3-4. Connecting the Power Cord	9
3-5. Turning Power On.....	10
3-6. Installing the Cable	11
3-7. Switch Blind Installation.....	11
3-8. Bluetooth Settings (For Bluetooth Interface Models only).....	12
4. Loading the Ribbon Cartridge and Paper.....	16
4-1. Loading the Ribbon Cartridge	16
4-2. Loading the paper	17
4-3. Installing the Roll Paper Guide	19
4-4. Setup Precautions	20
5. Control Panel and Other Functions.....	22
5-1. Control Panel.....	22
5-2. Basic Indicators.....	22
5-3. Errors	23
5-4. Adjustment Mode	25
6. Preventing and Clearing Paper Jams	31
6-1. Preventing Paper Jams	31
6-2. Removing Paper Jam.....	31
6-3. Releasing a Locked Cutter (Auto Cutter Mode only)	32

1. Unpacking and Installation

1-1. Unpacking

After unpacking the unit, check that all the necessary accessories are included in the package.

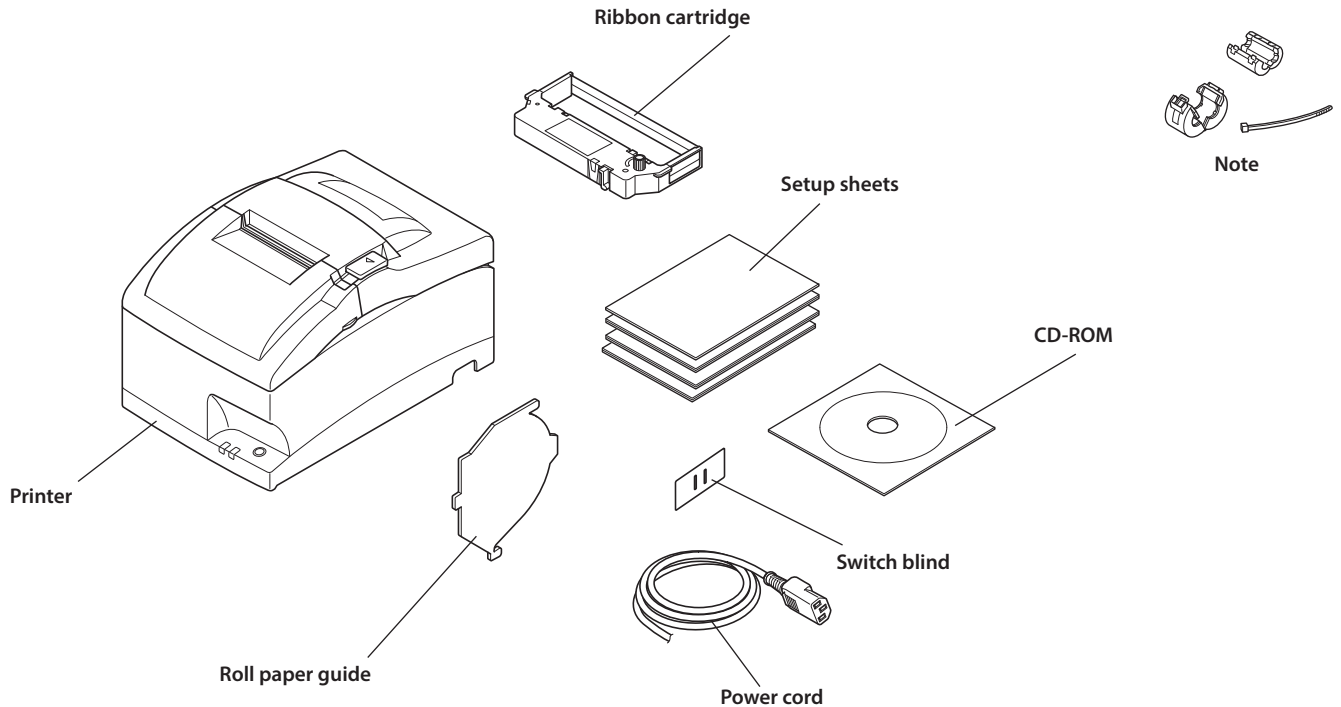

Note: The ferrite core and fastener provided with your printer depend on your printer configuration.

1-2. Notes about Installation

1. Choose a firm, level surface where the printer will not be exposed to vibration.
2. Make sure that the printer is connected to a reliable power outlet. It should not be on the same electric circuit as copiers, refrigerators, or other appliances that cause power spikes.
3. The power outlet you plan to connect to for power should be nearby and unobstructed.
4. Make sure that the printer is not exposed to direct sunlight.
5. Make sure that the printer is well away from heaters and other sources of extreme heat.
6. Do not locate the printer in a badly ventilated or dusty environment.
7. Make sure that the room where you are using the printer is not too humid.
8. This device employs a DC motor and switches that have an electrical contact point. Avoid using the device in environments where silicon gas can become volatile.
9. Use the printer within the boundaries indicated in the environmental requirements. Even when the ambient temperature and humidity are within the specifications, avoid radical changes in environmental conditions. The suitable operating temperature range is as follows:
Operating temperature: 0°C to 50°C
10. When disposing of the printer, obey local regulations.

1-3. Handling Care

1. Be careful not to drop paper clips, pins or other foreign matter into the unit as these cause the printer to malfunction.
2. Do not attempt to print when either paper or ribbon cartridge is not located in the printer, otherwise the print head can be damaged.
3. Do not open the cover while printing.
4. Do not touch the print head immediately after printing as it gets very hot.
5. Use only roll paper that is not glued to the core.
6. When the paper end mark appears on the paper, replace the roll paper before it runs out.

1-4. Maintenance

Essentially, your printer is a robust piece of equipment, but should be treated with a modicum of care in order to avoid malfunctions. For example:

1. Keep your printer in a “comfortable” environment. Roughly speaking, if you feel comfortable, then the environment is suitable for your printer.
2. Do not subject the printer to physical shocks or excessive vibration.
3. Avoid over-dusty environments. Dust is the enemy of all precision mechanical devices.
4. To clean the exterior of the printer, use a cloth barely dampened with either water with a little detergent or a little alcohol, but do not allow any liquid to fall inside the printer.
5. The interior of the printer may be cleaned with a small cleaner or a compressed-air aerosol (sold for this purpose). When performing this operation, be sure not to bend or damage any cable connections or electronic components.

2. Parts Identification and Nomenclature

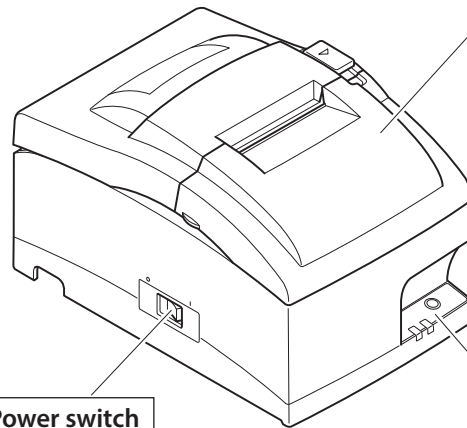

Printer cover

Protects the printer from dust and reduces noise. Do not open the cover while printing.

Power switch

Turns printer power on and off.

Control panel

Features one control switch and two indicators to indicate printer status.

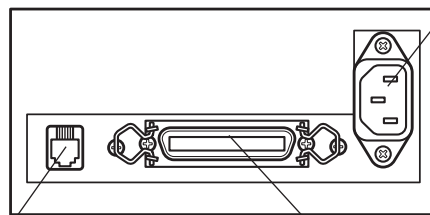

Power connector

For connection of the power cord.

Peripheral unit drive circuit connector

Connects to peripheral units such as cash drawers, etc. Do not connect this to a telephone.

Interface connector

Connects the printer with host computer.

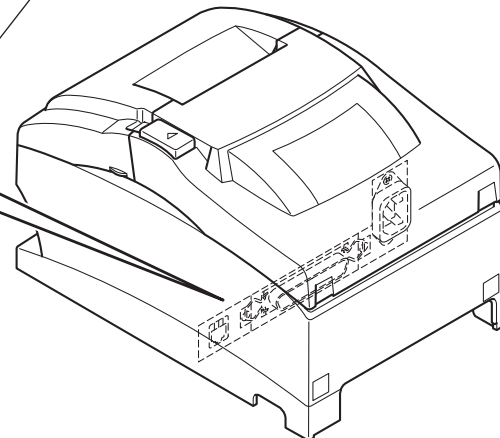

3. Setup

3-1. Connecting the Cable to the PC

3-1-1. Parallel Interface Cable

Connect the parallel interface cable to a parallel port of your PC.

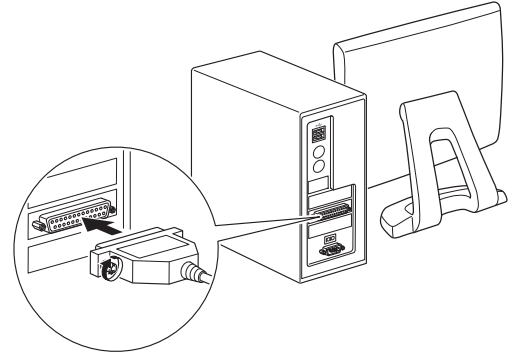

3-1-2. RC-232 Interface Cable

Connect the RC-232 interface cable to a RS-232 port of your PC.

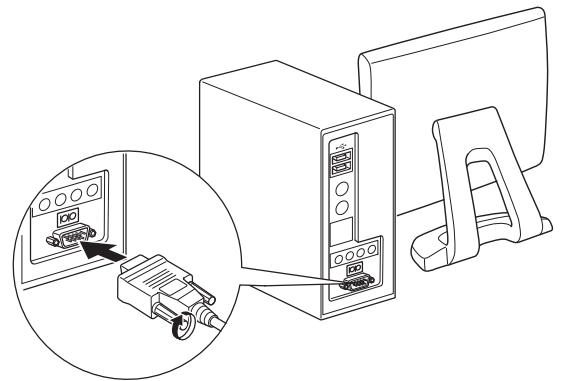

3-1-3. USB Interface Cable

Connect the USB interface cable to a USB port of your PC.

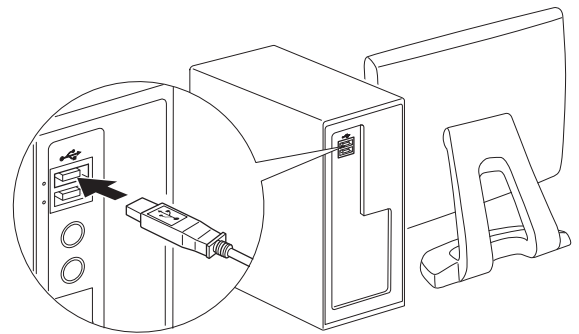

3-1-4. Ethernet Interface cable

Connect the ethernet interface cable to a ethernet port of your PC.

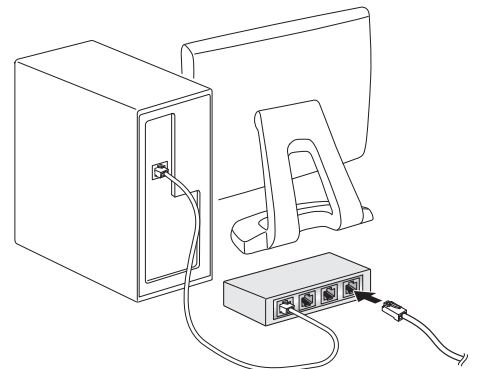

3-2. Connecting the Cable to the Printer

Note that the interface cable is not provided. Please use a cable that meets specifications.

⚠ CAUTION

Before connecting/disconnecting the interface cable, make sure that power to the printer and all the devices connected to the printer is turned off. Also make sure the power cable plug is disconnected from the AC outlet.

3-2-1. Parallel Interface Cable

- (1) Make sure the printer is turn off.
- (2) Affix the ferrite core onto the cable as shown in the illustration.
- (3) Pass the fastener through the ferrite core.
- (4) Loop the fastener around the cable and lock it. Use scissors to cut off any excess.

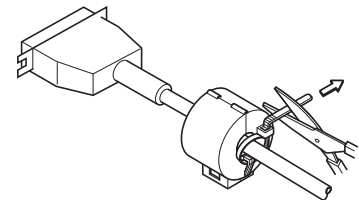
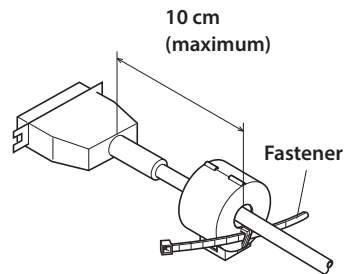
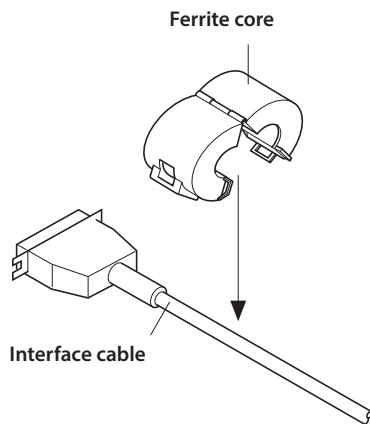
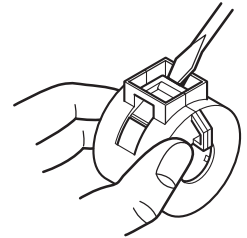

- (5) Connect the interface cable to the connector on the rear panel of the printer.
- (6) Fasten the connector clasps.

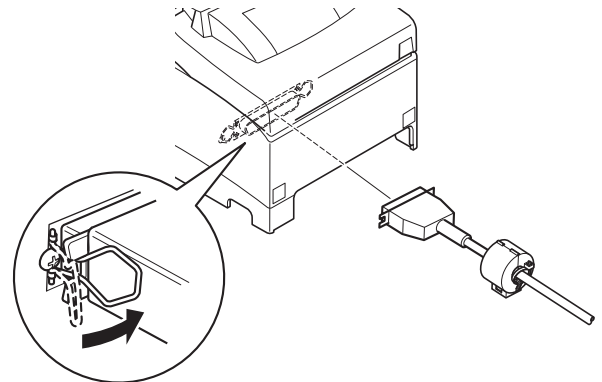

3-2-2. RS-232 Interface Cable

- (1) Make sure the printer is turn off.

⚠ CAUTION

Before connecting/disconnecting the interface cable, make sure that power to the printer and all the devices connected to the printer is turned off. Also make sure the power cable plug is disconnected from the AC outlet.

- (2) Connect the interface cable to the connector on the rear panel of the printer.
- (3) Tighten the connector screws.

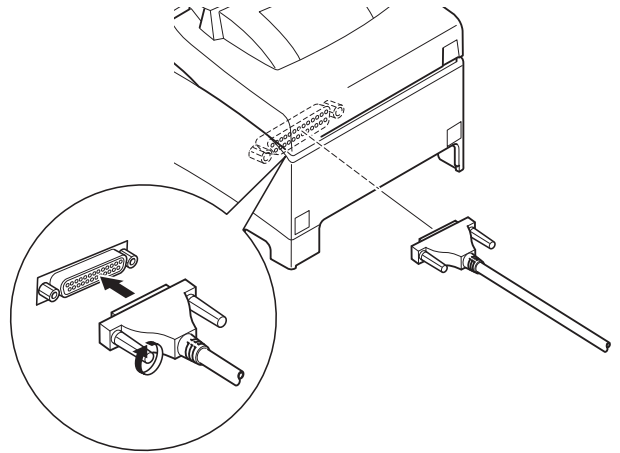

3-2-3. USB Interface Cable

Affix the ferrite core onto the USB cable as shown in the illustration below and make sure to pass the cable through the cable support as shown in the illustration.

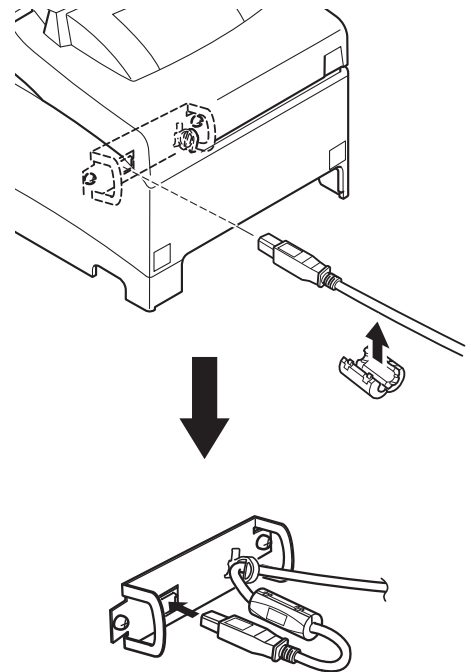

3-2-4. Connecting Ethernet Cable

If a ferrite core is included, install the ferrite core onto the Ethernet cable according to the following procedure to prevent electrical noise.

If a ferrite core is not included, perform steps (1) and (5) only.

- (1) Make sure the printer is turned off.
- (2) Affix the ferrite core onto the ethernet cable as shown in the illustration below.
- (3) Pass the fastener through the ferrite core.
- (4) Loop the fastener around the cable and lock it. Use scissors to cut off any excess.

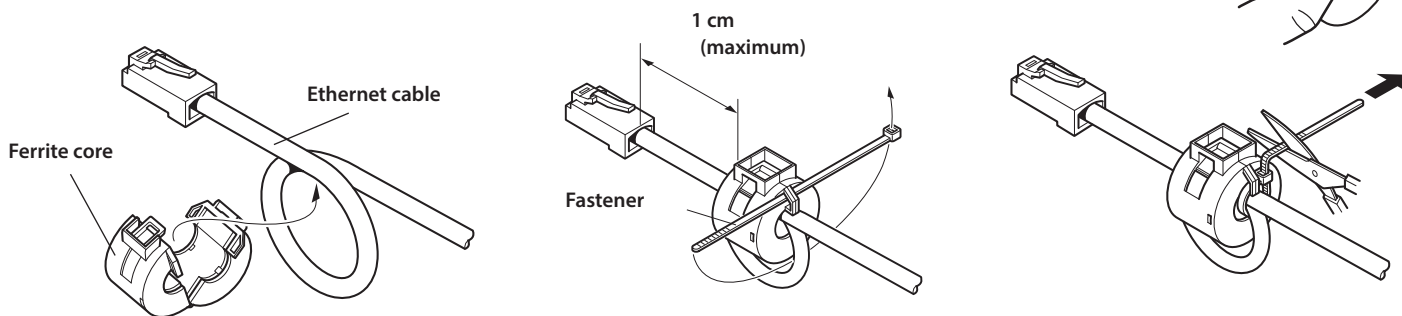

- (5) Connect the interface cable to the connector on the rear panel of the printer.

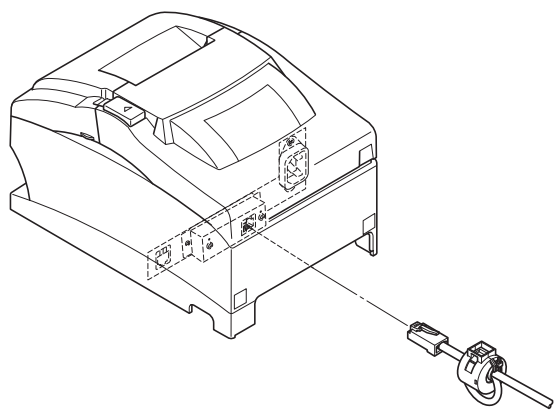

Ethernet Interface Board
IFBD-HE06

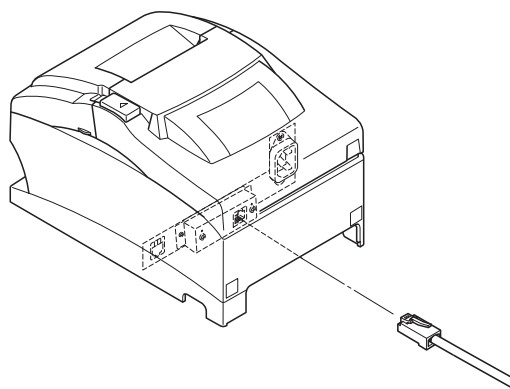

Ethernet Interface Board
IFBD-HE08

Link disconnection detection feature

The Ethernet interface model is equipped with a link disconnection detection feature. If the printer is turned on when an Ethernet cable is not connected to it, the POWER and ERROR lamps are simultaneously turned on and off at 2-second intervals to indicate the disconnection.

Be sure to connect the Ethernet cable from a PC or hub to the printer, and then turn the printer on.

3-3. Connecting to a Peripheral Unit

You can connect a peripheral unit to the printer using a modular plug. Note that this printer does not come with a modular plug or wire, so it is up to you to obtain one that suits your needs.

Important!

Make sure that the printer is turned off and unplugged from the AC outlet and that the computer is turned off before making connections.

- (1) Connect the peripheral drive cable to the connector on the rear panel of the printer.

Important!

Do not connect a telephone line into the peripheral drive connector. Failure to observe this may result in damage to the printer.

Also, for safety purposes, do not connect wiring to the external drive connector if there is a chance it may carry peripheral voltage.

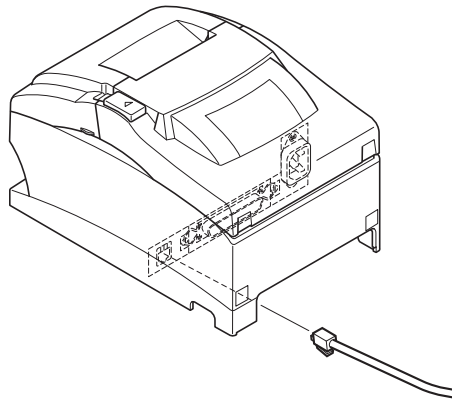

3-4. Connecting the Power Cord

Note: Before connecting/disconnecting the power cord, make sure that power to the printer and all the devices connected to the printer is turned off. Also make sure the power cable plug is disconnected from the AC outlet.

- (1) Check the label on the back or bottom of the printer to make sure its voltage matches that of the AC outlet. Also make sure the plug on the power cord matches the AC outlet.
- (2) If the power cord is not attached to the printer, plug the appropriate end into the AC inlet on the back of the printer.
- (3) Plug the power cord into a properly grounded AC outlet.

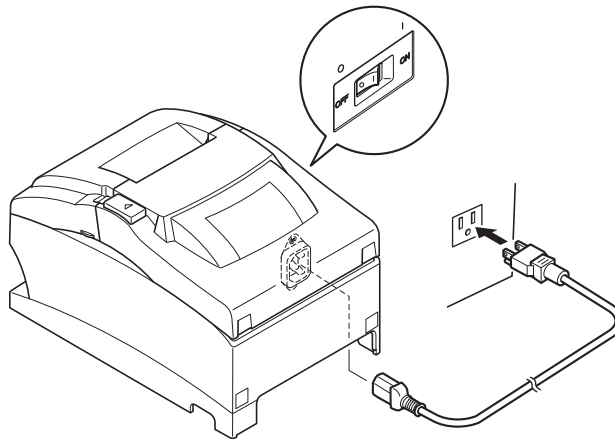

Important!

If the voltage shown on the label on the of your printer does not match the voltage for your area, contact your dealer immediately.

The power cord is designed for use with this printer only. Do not connect it to any other device.

3-5. Turning Power On

Make sure that the Power cord has been connected as described in "3-4. Connecting the Power Cord".

Turn ON the power switch located on the front of the printer.
The POWER lamp on the control panel will light up.

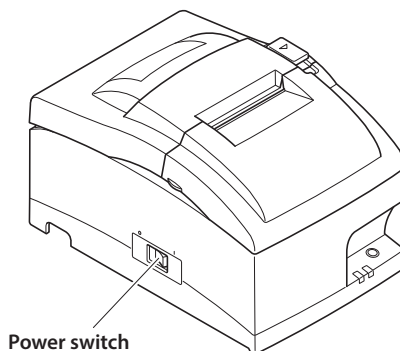

⚠ CAUTION

We recommend that you unplug the printer from the power outlet whenever you do not plan to use it for long periods. Because of this, you should locate the printer so that the power outlet it is plugged into is nearby and easy to access.

When an Switch blind is affixed to the printer above the power switch, the ON/OFF marks of the power switch may be hidden. If this occurs, remove the power cord from the outlet to turn the printer OFF.

3-6. Installing the Cable

Install the cable as shown in the diagram below.

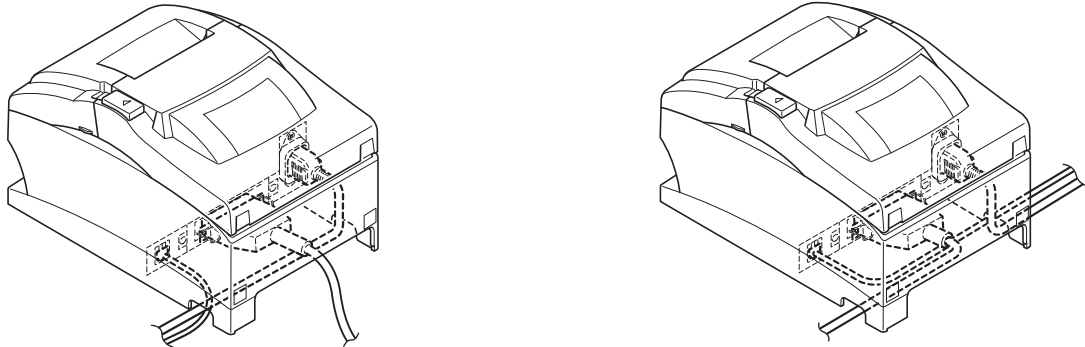

3-7. Switch Blind Installation

It is not necessary to install the switch blind. Only install it if it is necessary for you. By installing the switch blind, the following become possible.

- Preventing the power switch from being operated by mistake.
- Ensuring that other people can not easily operate the power switch.

Install the switch blind as shown in the diagram below.

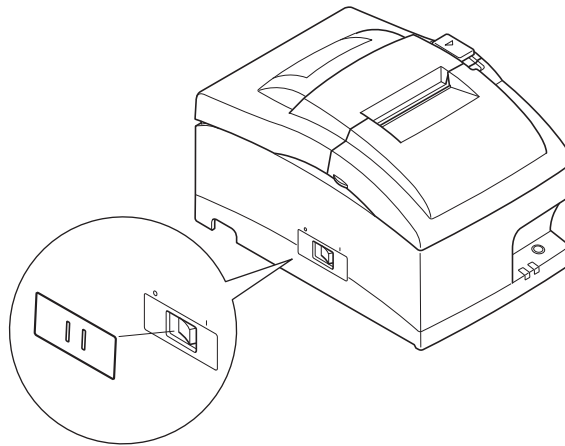

The power switch can be turned ON (I) and OFF (O) by inserting a narrow instrument (ball pen etc) in the holes in the switch blind.

Important!

We recommend that you unplug the printer from the power outlet whenever you do not plan to use it for long periods. Because of this, you should locate the printer so that the power outlet it is plugged into is nearby and easy to access.

3-8. Bluetooth Settings (For Bluetooth Interface Models only)

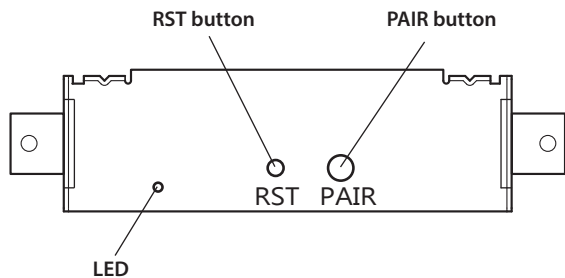

<LED> Indicates the status of the Bluetooth interface.
Green (on): Not connected.
Green (flashing): Ready to start pairing.
Blue (on): Connected.
Purple (flashing): Auto connection ON.

Pair the printer with the master device by following the procedure below.

3-8-1. Pairing using SSP (Simple Secure Pairing) [Default]

- (1) After turning the printer's power switch on, press and hold the PAIR button on the rear interface of the printer for 5 seconds or more, and then release it. The LED will flash green.

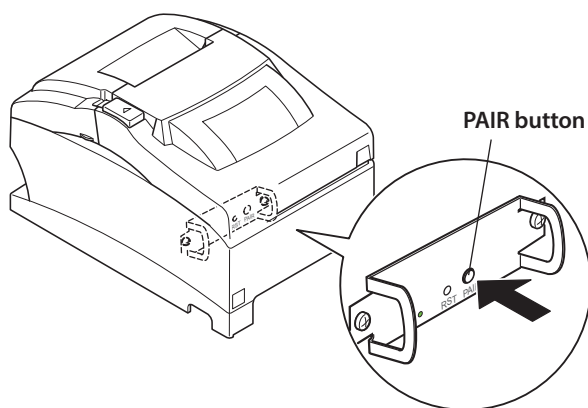

- (2) Pairing will be possible for 60 seconds from when the LED begins flashing green. During this time, perform pairing from the master device.
Device name: Star Micronics (default)
- (3) After performing pairing, wait until the LED stops flashing green, or turn the printer off and back on again, to enable the connection.
In the iOS devices, after pairing, the LED will automatically begin flashing blue, and the printer will be automatically connected.
- (4) Connect to the printer from the master device application and perform printing. If the printing is successful, the pairing process has been completed.

Note: The printer performs various processes immediately after connecting to or disconnecting from a master device.

Please wait approximately 0.1 seconds after connecting, and approximately 0.5 seconds after disconnecting, before beginning communications with the printer. This wait will ensure that the next action you perform is executed correctly.

3-8-2. Pairing using PIN code

Enter the following information in the master device if it does not support SSP, or when otherwise necessary.

PIN: 1234 (default)
Device name: Star Micronics (default)

It is recommended that you change the PIN code for greater security.

For details regard changing the PIN code, please see the “Software Manual -Star Bluetooth Utility-”.

3-8-3. Auto Connection Function (iOS only)

Each time the wireless connection is disconnected while communicating with upper-level iOS devices including iPad over Bluetooth, it is necessary to move back to the Bluetooth setting screen in the upper-level iOS device and tap the desired printer name again to build a connection. This is an iOS specification.

In order to save this labor, this printer is equipped with the Auto Connection function that automatically requests a connection from an upper-level iOS device that was connected to the printer last time.

You can also check the current ON/OFF setting by performing self-printing.

Caution: If "Auto Connection function" is set to ON when using devices other than iOS, a Bluetooth communication with the printer may fail. To use devices other than iOS, such as the Android/Windows devices, make sure you turn off the "Auto Connection" function before using the printer.

For information on how to set up this function, see "3-8-4. Setting up Auto Connection".

	Auto Connection ON	Auto Connection OFF
Reconnecting without changing the parent device	After the printer is turned on, it automatically connects to the last parent device that was connected.	After turning on the printer, tap this printer's name on the Bluetooth settings screen on the parent device.
Changing the connected parent device	Disconnect the Bluetooth connection in such a way as to turn OFF the power to the upper-level device automatically connected. Then, establish a pairing with a desired upper-level device.	After turning on the printer, establish a pairing with a desired upper-level device.
Example (recommended)	When connecting directly to the printer from one parent device.	When using the printer with multiple parent devices.

3-8-4. Setting up Auto Connection

◆ Setting up from the Main Unit for the SP742

Note: The following procedure explains how to change the Auto Connection function setting from ON to OFF.

If you want to change it from OFF to ON, please follow the same procedure.

- (1) When paper is loaded in the printer and it is turned on, the [POWER] LED(green) on the front of the printer turns on.
- (2) If you hold down the [RST] button on the back of the printer for at more than five seconds, initial operations are performed in the same way as when the power is turned on, and the LEDs on the front of the printer flash. If you press the [RST] button when the printer is placed upright, place it horizontally again while the LED is flashing.

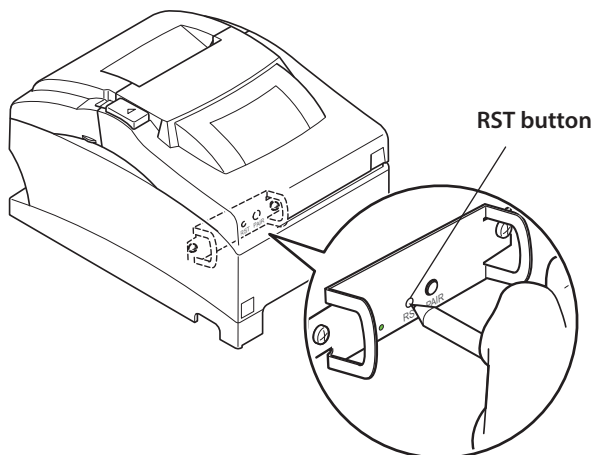

- (3) The following information is printed. After that, turn the printer off and then back on again to set "Auto Connection" to OFF.

```
< Current Setting >
Auto Connection : OFF

To enable this setting, turn
Printer Power OFF and turn ON.
```

- (4) To make sure "Auto Connection" is set to OFF correctly, perform self-printing as described in "5-4-1. Self Printing Mode"

◆ Setting from the Software

After pairing your device and the SP700, change "Auto Connection" in the following application provided by our company.

- **iOS:** Download "Star Setting Utility" from the following Web site.
<http://www.star-m.jp/prjump/000003.html>
- **Android:** Download "Star Setting Utility" from the following Web site.
<http://www.star-m.jp/prjump/000004.html>
- **Windows:** Download "Star Bluetooth Utility" from the following Web site.
<http://www.star-m.jp/prjump/000006.html>

3-8-5. Resetting Bluetooth Settings

The PIN code, device name, and other settings can be reset by following the procedure given below.

- (1) Use a fine pointed pen or other similar object to press and hold the RST button. While holding the RST button, turn the printer's power switch on.
- (2) The reset process will begin, and the LED at the front of the printer will flash green. When the settings have been reset, the LED will stop flashing.
- (3) Turn the printer's power switch off, and delete the pairing settings from the master device.

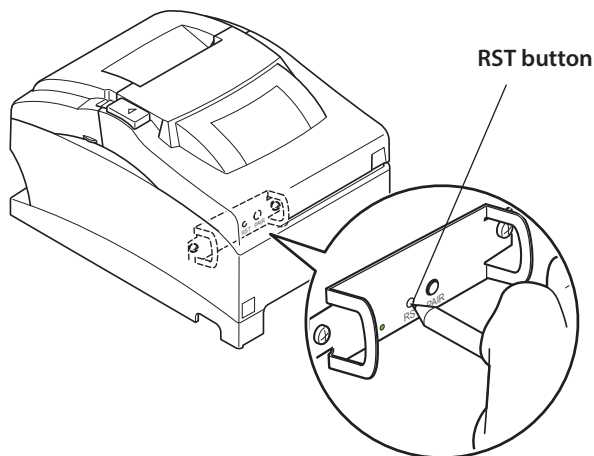

“Made for iPod”, “Made for iPhone” and “Made for iPad” mean that an electronic accessory has been designed to connect specifically to iPod, iPhone, or iPad, respectively, and has been certified by the developer to meet Apple performance standards.

Apple is not responsible for the operation of this device or its compliance with safety and regulatory standards.

iPod is a trademarks of Apple Inc., registered in the U.S. and other countries. iPod touch, iPad and iPhone are trademark of Apple Inc.

iPod, iPhone and iPad compatibility list

Made for

- iPod touch (5th generation)
- iPod touch (4th generation)
- iPhone 5S
- iPhone 5C
- iPhone 5
- iPhone 4S
- iPhone 4
- iPad Air
- iPad (4rd generation)
- iPad (3rd generation)
- iPad 2
- iPad
- iPad mini with Retina display
- iPad mini

Note: as of July, 2014

4. Loading the Ribbon Cartridge and Paper

4-1. Loading the Ribbon Cartridge

- ① Turn off power to the printer.
- ② Open the front cover by holding the finger grips on both ends of the cover and lifting it up.

Important!

1. Do not touch the print head immediately after printing as it can be extremely hot.
2. Do not touch the cutter blade.
 - There is a cutter inside the paper outlet slot. Not only should you not put your hand in the paper outlet slot while printing is in progress, never put your hand into the outlet even when printing is not in progress.

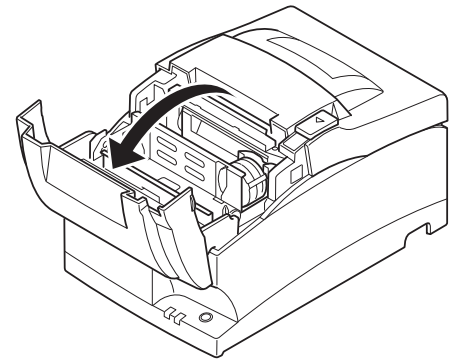
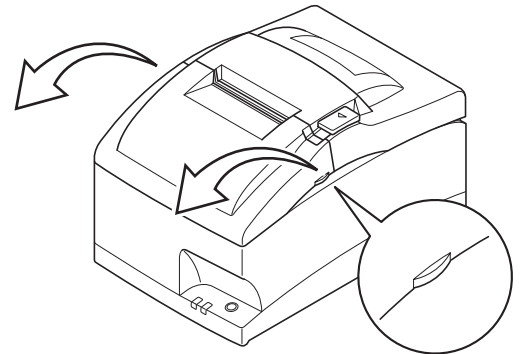

- ③ Place the ribbon cartridge in the direction shown in the figure and press it down to load it. If loading of the ribbon cartridge is not satisfactory, press down the cartridge while rotating the ribbon feed knob in the direction of the arrow.
- ④ Turn the ribbon feed knob of the ribbon cartridge in the direction of the arrow to remove slack in the ribbon.

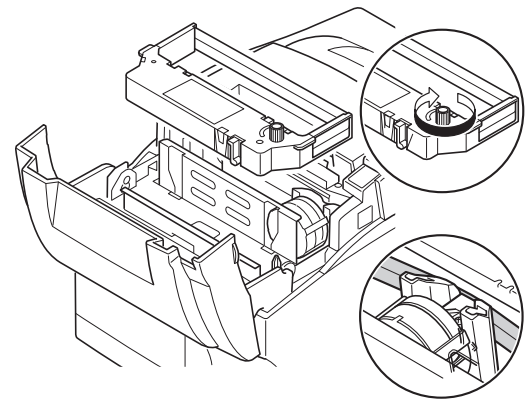

- ⑤ Close the front cover.

Note: When removing the ribbon cartridge, raise the finger grips as shown in the figure.

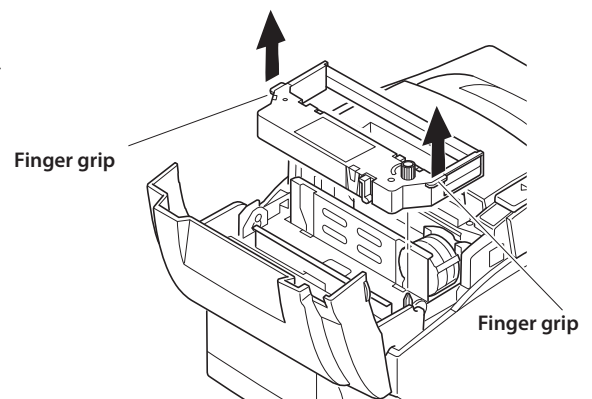

4-2. Loading the paper

Use a paper roll that complies with the printer specifications.

- ① Open the printer cover by sliding the latch toward you.

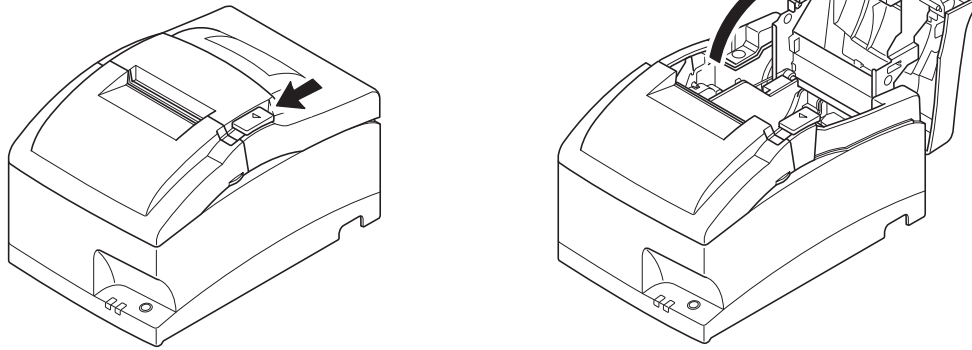

Important!

1. Do not touch the print head immediately after printing as it can be extremely hot.

2. Do not touch the cutter blade.

- There is a cutter inside the paper outlet slot. Not only should you not put your hand in the paper outlet slot while printing is in progress, never put your hand into the outlet even when printing is not in progress.
-

- ② While observing the direction of the roll, set the paper roll into the hollow, and pull on the leading edge of the paper toward you.

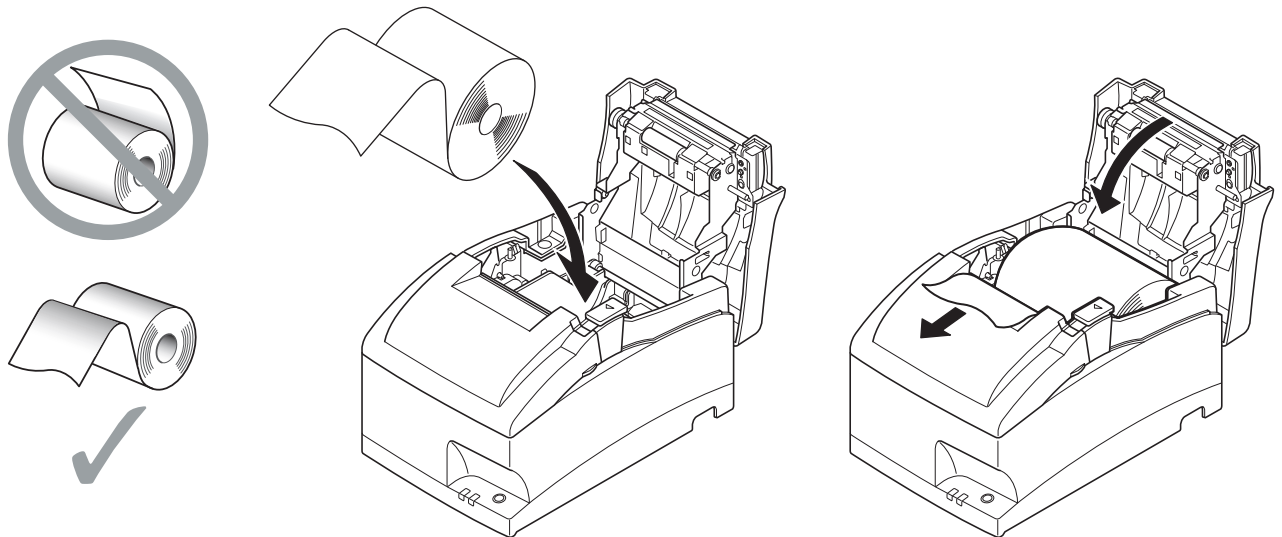

- ③ Push down both sides of the printer cover to close.

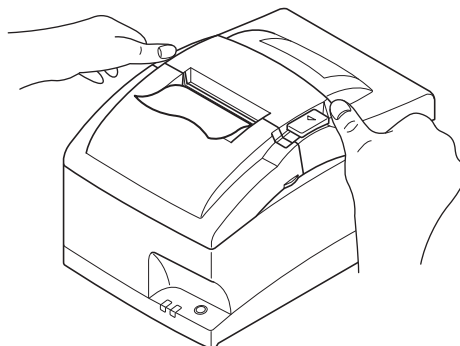

Note: Make sure that the printer cover is securely closed.

- ④ **Tear Bar Model:**
Tear off the paper as shown.

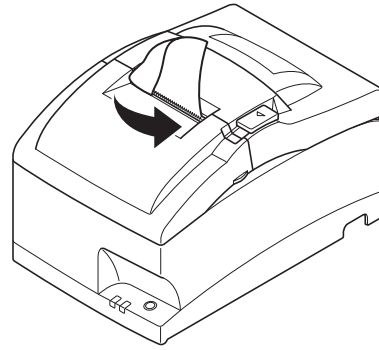

Auto Cutter Model:

If the printer cover is closed after turning on the power, the cutter operates automatically and the front end of the paper is cut.

Note: When the paper end mark appears on the paper, replace the roll paper before it runs out.

4-2-1. Compliant Paper Roll Specifications

Paper type	Ordinary bond and carbonless copy paper
Paper width	76±0.5 mm (3.0 inches)/57.5±0.5 mm (2.25 inches)/69.5±0.5 mm (2.75 inches)
Thickness	
• Single	0.06 mm to 0.085 mm
• Copies	Original + 2 copies (Max. 0.2 mm)
Roll diameter	85mm (3.35 inches) max.
Core	12±1 mm (Inner dia.), 18±1 mm (Outer dia.)

Note 1: Do not glue or tape the paper roll and shaft core together.

2: Do not fold the tail end of the paper.

4-3. Installing the Roll Paper Guide

When using paper roll with 57.5 mm or 69.5 mm width, install the attached roll paper guide in the groove in the printer. The setting for memory switch 2-A and 2-B must be changed to change the print width.

When you change the effective print width (paper roll width), change the printer utility's memory switch setting. For details, see the printer utility help.

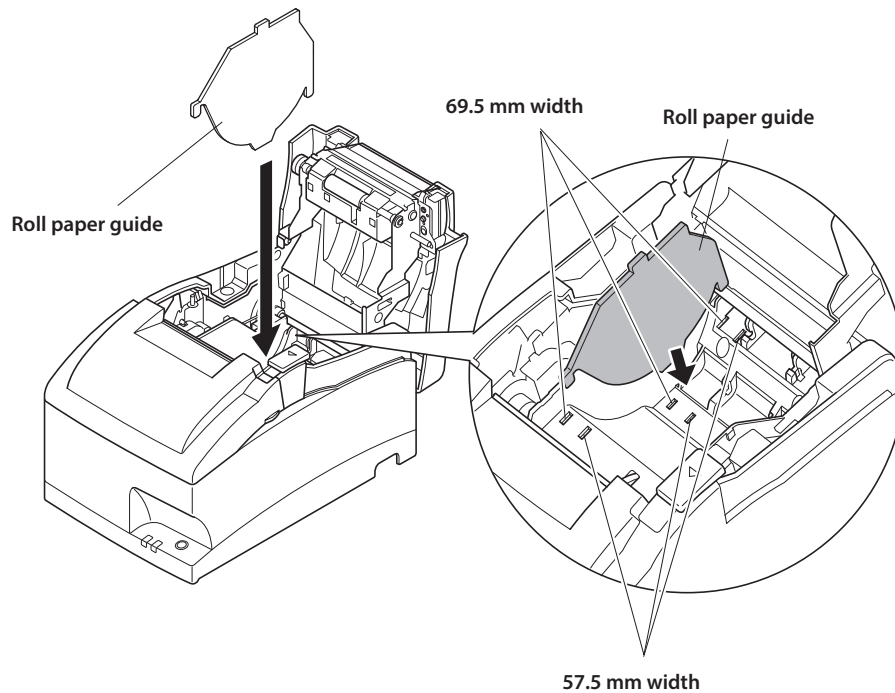

4-4. Setup Precautions

WARNING

- ✓ Shut down your equipment immediately if it produces smoke, a strange odor, or unusual noise. Immediately unplug the equipment and contact your dealer for advice.
- ✓ Never attempt to repair this product yourself. Improper repair work can be dangerous.
- ✓ Never disassemble or modify this product. Tampering with this product may result in injury, fire, or electric shock.
- ✓ Do not touch the cutter blade.
 - There is a cutter inside the paper outlet slot. Not only should you not put your hand in the paper outlet slot while printing is in progress, never put your hand into the outlet even when printing is not in progress.
 - The printer cover can be opened when replacing the paper. However, since the cutter blade is on the inside of the printer cover, be careful not to place your face or hands too close to the cutter blade.
- ✓ During and immediately after printing, the area around the print head is very hot. Do not touch it, as you could be burned.
- ✓ Since working on the cutter may be dangerous, be sure to turn off the printer first.

CAUTION

- ✓ We recommend that you unplug the printer from the power outlet whenever you do not plan to use it for long periods. Because of this, you should locate the printer so that the power outlet it is plugged into is nearby and easy to access.
- ✓ If the voltage shown on the label on the of your printer does not match the voltage for your area, contact your dealer immediately.
- ✓ Make sure that the printer is turned off and unplugged from the AC outlet and that the computer is turned off before making connections.
- ✓ Do not connect a telephone line into the peripheral drive connector.
Failure to observe this may result in damage to the printer.
Also, for safety purposes, do not connect wiring to the external drive connector if there is a chance it may carry peripheral voltage.
- ✓ Do not operate the cover open lever while pressing on the printer cover with your hand.
- ✓ Do not pull the cover open lever and open the printer cover when printing is in progress or when the auto cutter is operating.
- ✓ Do not pull out paper while the printer cover is closed.
- ✓ If liquids, foreign objects (coins and paper clips), and so on enter the printer, turn off the printer, unplug it from the AC outlet, and contact your dealer for advice. Continued use could cause a short circuit, which may result in fire or electric shock.
- ✓ Place the printer in a horizontal position when installing the paper, even if the model can be installed vertically. If the paper is installed with the printer in a vertical position, the printer will be unstable and could fall, which may result in injury.

CAUTION

Wireless Communication

- ✓ Do not use the device where using wireless devices is prohibited or may cause interference or danger.
- ✓ The radio waves generated by the device may interfere with the operation of electronic medical devices. If you are using any electrical medical device, contact its manufacturer for the restrictions on the use of the device.
- ✓ Security functionality for Bluetooth is installed in this product. Configure the security settings according to the manual (available on the Star Micronics website) to reduce the risk of security issues.
- ✓ This device supports Bluetooth.
Since this functionality may be limited by local regulations, first review the radio laws specific to the country in which the product will be used.
- ✓ Below is a list of laws this device has been approved by. As Star Micronics is committed to constant innovation, revisions may be made without an announcement. Access the Star Micronics website for the latest listing of approvals.
- ✓ Please refer to Star Micronics website for the latest information and manuals.

5. Control Panel and Other Functions

5-1. Control Panel

- ① POWER lamp (Green LED)
Lights when the power is ON.
- ② FEED button
Press the FEED button to feed roll paper.
- ③ ERROR lamp (Red LED)
Indicates various errors in combination with POWER lamp.

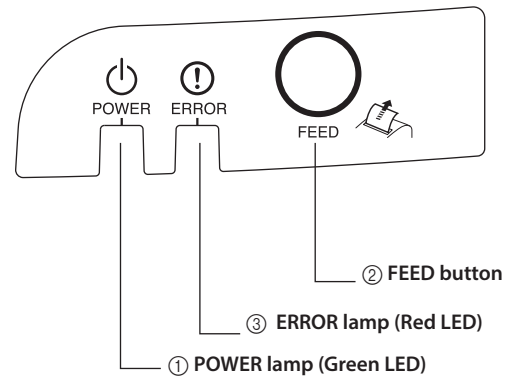

5-2. Basic Indicators

	POWER lamp	ERROR lamp	Buzzer
Power On/Off	On/Off	—	—
No Error	On	Off	—

5-3. Errors

1) Recoverable error

Error Description	POWER lamp	ERROR lamp	Buzzer	Recovery Conditions
Paper end error	On	Flashes (On: 1 sec./Off: 1 sec.)	4 short beeps (0.13 sec.) repeated twice	*1
Printer cover open error	On	On	Beep	*2
Front cover open error	Flashes (On: 0.5 sec./Off: 0.5 sec.)	On	Beep	*3
Head high temperature detection	Flashes (On: 1 sec./Off: 1 sec.)	Off	None	*4
Board high temperature detection	Flashes (On: 2 sec./Off: 2 sec.)	Off	None	*5
Cutter error (on models with cutter)	On	Flashes (On: 0.125 sec./Off: 0.125 sec.)	3 short beeps (0.13 sec. + 0.13 sec. + 0.5 sec.)	*6
Mechanical error (other than cutter error)	On	Flashes (On: 0.25 sec./Off: 0.25 sec.)	2 short beeps (0.13 sec. + 0.5 sec.)	*7
Black mark detection error	On	Flashes (On: 0.5 sec./Off: 0.5 sec.)	3 short beeps (0.13 sec. + 0.13 sec. + 0.13 sec.)	*8
Link disconnection detection (Physical link disconnection)	Flashes at 2-second intervals	Flashes at 2-second intervals	—	*9
Link disconnection detection (IP address lost)	Flashes at 0.125-second intervals	Flashes at 0.125-second intervals	—	*10

*1 Automatically recovered by loading a new paper roll, then closing the printer cover.

*2 Automatically recovered by closing the printer cover.

*3 Automatically recovered by closing the front cover.

*4 Automatically the printer is recovered after the print head has cooled.

A print head temperature error is not abnormal.

*5 Automatically the printer is recovered after the board has cooled.

*6 Automatically the printer is recovered if the cutter returns to the home position after turning the power OFF and ON.

Restoration is also possible with the <DLE> <ENQ> n command when in the ESC/POS mode.

Note

- 1) If the cutter doesn't return to the home position, or doesn't perform the initial movement, it cannot be recovered.
- 2) If the paper is jammed, turn the power OFF, clear the jammed paper, then turn the power ON.
- 3) When the error occurs:
 STAR Mode: Non recoverable error
 ESC/POS Mode: Recoverable error

*7 Turn the power OFF, clear the jammed paper or remedy another problem and then turn the power ON. Automatically the printer is recovered if the carriage returns to the home position after turning the power OFF and ON.

Restoration is also possible with the <DLE> <ENQ> n command when in the ESC/POS mode.

When the error occurs:

- STAR Mode: Non recoverable error
- ESC/POS Mode: Recoverable error

*8 For paper jam errors:

Clear the jammed paper and change the paper roll if necessary.

For incorrect paper format errors:

Change the paper roll and use a paper roll with the correct black mark.

*9 Connect an Ethernet cable. For details, see section "3-2-4. Connecting Ethernet Cable"

※Ethernet interface model only

*10 Set the correct IP address and restart the printer.

※Ethernet interface model only

2) Non recoverable error

Error Description	POWER lamp	ERROR lamp	Buzzer
Flash memory write error	Off	Flashes (On: 1 sec./ Off: 1 sec.)	None
Thermistor failure error	Off	Flashes (On: 0.25 sec./ Off: 0.25 sec.)	2 short beeps (0.13 sec. + 0.5 sec.)
Power supply error	Off	Flashes (On: 2 sec./ Off: 2 sec.)	None
CPU error	Off	On	One long beep (2 sec.)
RAM R/W error	Off	On	None

Note

If a non-recoverable error occurs, turn the power OFF, wait at least 10 seconds, and turn the power back ON. If the non-recoverable error continues to be indicated, consult a dealer for repairs.

5-4. Adjustment Mode

There are the following seven adjustment modes.

The device will enter the adjustment mode if you turn it on while pressing the FEED switch.

- (1) The Self Printing Mode is entered by releasing the FEED switch after the buzzer sounds once. (Refer to Section "5-4-1. Self Printing Mode".)



- (2) Adjusting the Dot Alignment Mode is entered by releasing the FEED switch after the buzzer sounds twice. (Refer to Section "5-4-2. Adjusting the Dot Alignment Mode".)



- (3) The Hexadecimal Dump Mode is entered by releasing the FEED switch after the buzzer sounds three times. (Refer to Section "5-4-3. Hexadecimal Dump Mode".)

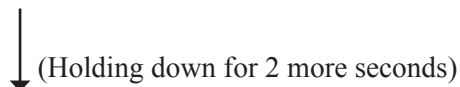

- (4) The Black Mark Sensor Alignment Mode is entered by releasing the FEED switch after the buzzer sounds four times. (Refer to Section "5-4-4. Black Mark Sensor Alignment Mode".)



- (5) The Near End Sensor Adjustment Mode is entered by releasing the FEED switch after the buzzer sounds five times. (Refer to the separate Specifications Manual for details.)

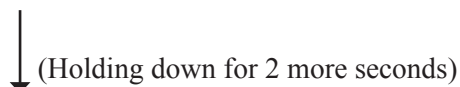

- (6) The Memory Switch Manual Setting Mode is entered by releasing the FEED switch after the buzzer sounds six times. (Refer to the separate Specifications Manual for details.)



- (7) The Memory Switch Override Mode is entered by releasing the FEED switch after the buzzer sounds seven times. (Refer to the separate Specifications Manual for details.)



Returns to (1).

5-4-1. Self Printing Mode

Self-printing will be performed to print the Ver. No. and printer settings. ASCII-printing will be repeated when the FEED switch is held continuously at the end of ASCII-printing. The self-printing mode will end automatically when the FEED button is released at the end of ASCII-printing.

```
** 57

Interface : Parallel

Memory Switch
  FEDCBA9876543210 HEX.
<0> 0000000000000000 0000
<1> 0000000000000000 0000
<2> 0000000000000000 0000
<3> 0000000000000000 0000
<4> 0000000000000000 0000
<5> 0000000000000000 0000
<6> 0000000000000000 0000
<7> 0000000000000000 0000
      00000000 0000
      0000 0000

<0> 4 = Model : 
<0> B-A = ESC 4 (Ank
<0> 9 = <SP> Red : Valid
<0> 2-3 = <FF> : Form Feed
<1> 8 = Black Mark : Invalid
<1> 4 = Zero Style : Normal Zero
<1> 0-3 = International: USA
<2> 0-8 = Print Width : 210 Del
```

5-4-2. Adjusting the Dot Alignment Mode

You may never have to use the procedure described in this section, but after you have been using your printer for some time you may find that the dots of some graphics do not align correctly. For example, what should look like:

```
  H H H
  | | |
  H H H
```

may come out looking like one of the following:

```
  H H H
```

or like this

```
  H H H
```

This is caused when mechanical parts of the printer get out of alignment. This happens only rarely and you may never experience it at all throughout the life of the printer. If you do have problems, use the following procedure to correct it.

- (1) Enter the Dot Alignment Adjust Mode according to the procedure described in Section "5-4. Adjustment Mode".
- (2) After entering the Dot Alignment Adjust Mode, a printout of the adjustment patterns similar to the printout below will be printed. The asterisk indicates the current adjustment pattern.

```
Dot Alignment Adjust Mode

1:
 2 - 4 Sec --> Backward
 4 - 1 Sec --> Forward
2: Lv.51
} } } } } } } } } } } } } } } } } } } } } }
3: Lv.52
} } } } } } } } } } } } } } } } } } } } } }
4: Lv.53
} } } } } } } } } } } } } } } } } } } } } }
5: Lv.54
| | | | | | | | | | | | | | | | | | | | | |
6: Lv.55
| | | | | | | | | | | | | | | | | | | | | |
7: Lv.56
| | | | | | | | | | | | | | | | | | | | | |
* 8: Lv.57
| | | | | | | | | | | | | | | | | | | | | |
9: Lv.58
| | | | | | | | | | | | | | | | | | | | | |
10: Lv.59
| | | | | | | | | | | | | | | | | | | | | |
11: Lv.60
| | | | | | | | | | | | | | | | | | | | | |
12: Lv.61
| | | | | | | | | | | | | | | | | | | | | |
13: Lv.62
{ { { { { { { { { { { { { { { { { { { { { {
14: Lv.63
{ { { { { { { { { { { { { { { { { { { { { {
15: Lv.64
{ { { { { { { { { { { { { { { { { { { { { {
16: Lv.65
{ { { { { { { { { { { { { { { { { { { { { {
17: Lv.66
{ { { { { { { { { { { { { { { { { { { { { {
18: Lv.67
{ { { { { { { { { { { { { { { { { { { { { {
19: Lv.68
{ { { { { { { { { { { { { { { { { { { { { {
20: Lv.69
{ { { { { { { { { { { { { { { { { { { { { {
21: Lv.70
{ { { { { { { { { { { { { { { { { { { { { {
22: Lv.71
{ { { { { { { { { { { { { { { { { { { { { {
23: Lv.72
{ { { { { { { { { { { { { { { { { { { { { {
```

- (3) To adjust, use the FEED switch to select the adjustment pattern from the printout with the smallest gap between the first printing pass and the return printing pass. Press the FEED switch once to specify the first adjustment pattern, twice to specify the second adjustment pattern, and so on up to seven times to specify the seventh adjustment pattern.

At the number that you want to specify, press and hold (2 seconds) the FEED switch until the long buzzer sounds. This will specify the setting value. (For example, if you want to select the eighth pattern from the top, press the FEED switch seven times. Then, at the eighth pattern, press and hold (2 seconds) the FEED switch until the long buzzer sounds.)

There are only twenty three adjustment patterns. The buzzer will sound each time the FEED switch is pressed. However, if you press the FEED switch more than twenty three times, a warning alert will sound.

- (4) If there is no matching pattern among the adjustment patterns, perform the “Backward” or “Forward” operation described below in order to print a printing pattern in which the dot alignment settings are changed. Then, repeat step (3).

Backward:

Press and hold the FEED switch for 2 to 4 seconds. The buzzer will beep, and the printer will print a pattern in which the forward is adjusted more leftward of the presently indicated pattern and the backward is adjusted more rightward.

Forward:

Press and hold the FEED switch for 4 seconds or longer. The buzzer will beep-beep, and the printer will print a pattern in which the forward is adjusted more rightward of the presently indicated pattern and the backward is adjusted more leftward.

- (5) After selecting the adjustment pattern, the setting value is stored in the non-volatile memory. A printout similar to the one below with the selected adjustment pattern highlighted and the message “Adjust Completed!” will be printed.

Note: Before the printout is printed, the setting value is stored in the non-volatile memory of the printer after the adjustment pattern has been selected and the long buzzer sounds. During this period, do not set the power switch to off. If this power switch is set to off when the setting value is being stored in the non-volatile memory, the setting value for the adjustment pattern and all of the memory switch settings will be reset.

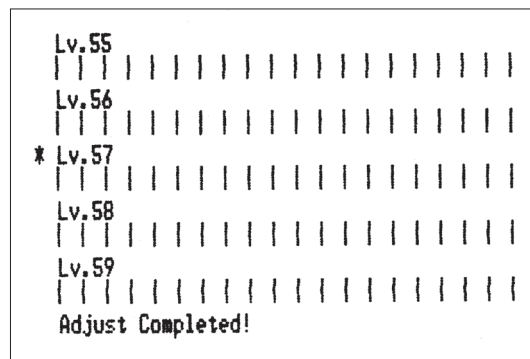

- (6) The long buzzer sounds once more and the setting value is automatically set. The adjusting the dot alignment mode is complete.

5-4-3. Hexadecimal Dump Mode

Each of the signals sent from the computer to the printer will be printed out in hexadecimal code.

This function allows you to check if a control code sent to the printer by the program being used is correct or not. The last line is not printed if its data is less than one full line. However, if the FEED switch is pressed, the last line will be printed. To turn off the mode, it is necessary to turn off the printer completely.

```
//// Hexadecimal Dump ////  
  
00 01 02 03 04 05 06 07      .....  
08 09 0A 0B 0C 0D 0E 0F      .....  
10 11 12 13 14 15 16 17      .....  
18 19 1A 1B 1C 1D 1E 1F      .....  
20 21 22 23 24 25 26 27      !"#$%&'  
28 29 2A 2B 2C 2D 2E 2F      ()*+,-./  
30 31 32 33 34 35 36 37      01234567  
38 39 3A 3B 3C 0A           89:;<.
```

5-4-4. Black Mark Sensor Alignment Mode

1. Turn the printer off and unplug the power cord.
2. Place the printer upright as shown below to remove the screws and remove the dip switch cover from the bottom of the printer. Be sure to place the printer upright because you will not be able to properly adjust the printer if it is placed on its side.

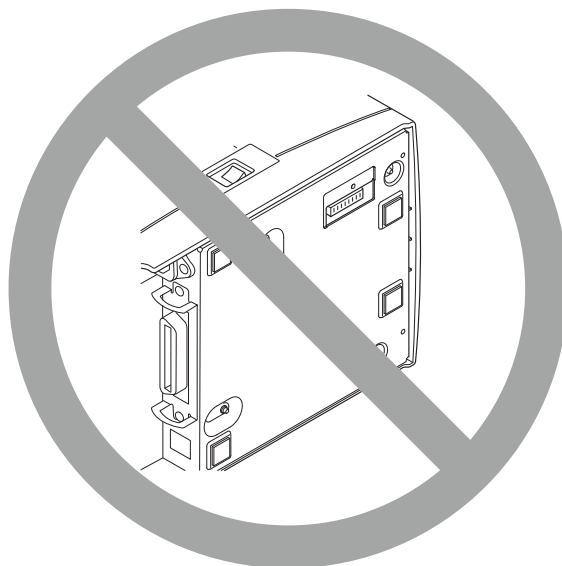
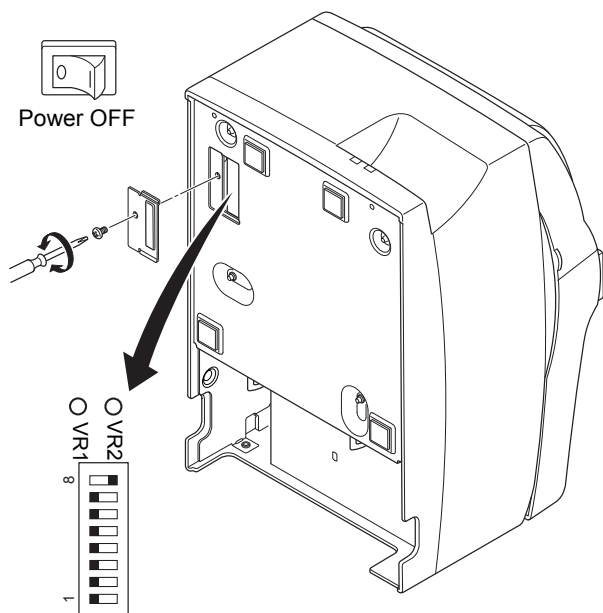

3. Since it is adjusted by rotating the volume VR2, check the position of the volume. Prepare a small slotted screwdriver that will fit in the hole.
4. Set the roll paper not for black mark.
5. Enter the black mark sensor adjustment mode according to the procedure described "5-4. Adjustment Mode".
6. Rotate the volume VR2 using micro screwdriver, to adjust it to a position whereat both the ERROR (red LED) and the POWER (green LED) lamps light.
7. Turn the power OFF.

This completes the black mark sensor adjustment.

6. Preventing and Clearing Paper Jams

6-1. Preventing Paper Jams

The paper should not be touched during ejection and before it is cut.

Pressing or pulling the paper during ejection may cause a paper jam, paper cutting failure or line feed failure.

6-2. Removing Paper Jam

If a paper jam occurs, clear it as described below.

- (1) Set the power switch to off to turn off power to the printer.
- (2) Push the cover open lever, and open the printer cover.
If the printer cover will not open on an auto cutter model, it means that the auto cutter is not in the home position (or locked). In this case, return the auto cutter to the home position by following the instructions provided in Section "6-3. Releasing a Locked Cutter (Auto Cutter Mode only)".
- (3) Remove the jammed paper.

CAUTION

Take care not to damage the printer when removing the jammed paper.

- (4) Position the roll paper straight and close the printer cover gently.
Note 1: Make sure that the paper is positioned straight. If the printer cover is closed with the paper skewed, a paper jam may result.
Note 2: Lock the printer cover by pressing down on the sides. Do not try to close it by pressing down on the center. The cover may not lock properly.
- (5) Set the power switch to on to turn on power to the printer. Make sure that the ERROR LED is not lit.
Note: While the ERROR LED is lit, the printer will not accept any commands such as the print command, so make sure that the printer cover is locked properly.

6-3. Releasing a Locked Cutter (Auto Cutter Mode only)

If the auto cutter locks up or fails to cut the paper, follow the steps below.

⚠ WARNING

Since working on the cutter may be dangerous, be sure to turn off the printer first.

- (1) Set the power switch to OFF to turn off the printer.
- (2) Ordinarily, a locked cutter will recover automatically by closing all the covers and turning the power back ON. Recovery means that the locked cutter has been released, so steps (3) and thereafter are unnecessary. If the cutter has not recovered, proceed to step (3).
- (3) Pull the cover open lever towards you, and open the printer cover. The printer cover may not open due to the cutter being locked. In this case, follow steps (4) and (5) to first open the front cover and remove the tear bar. If the printer cover opens, proceed to step (6).

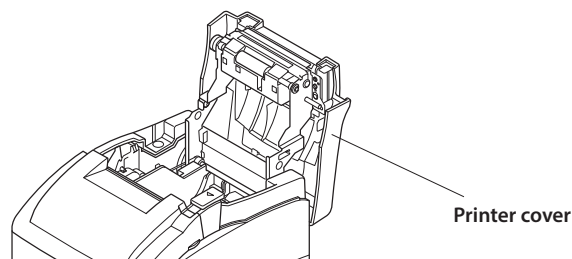
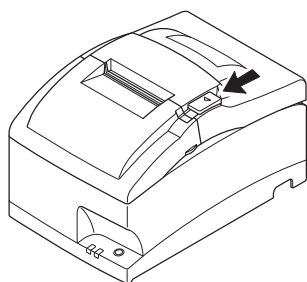

Note: Since the print head is hot immediately after printing, be sure not to touch it. On an auto cutter model, a paper cutter is located at the paper outlet slot. Be careful not to touch the cutter blade.

- (4) Open the front cover by holding the finger grips on both ends of the cover and lifting it up.

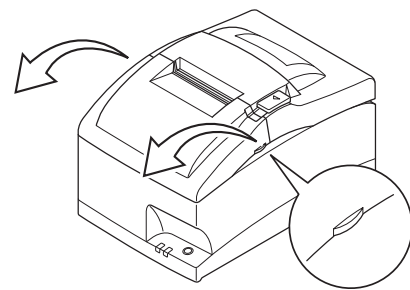

- (5) Remove the two screws to remove the tear bar.

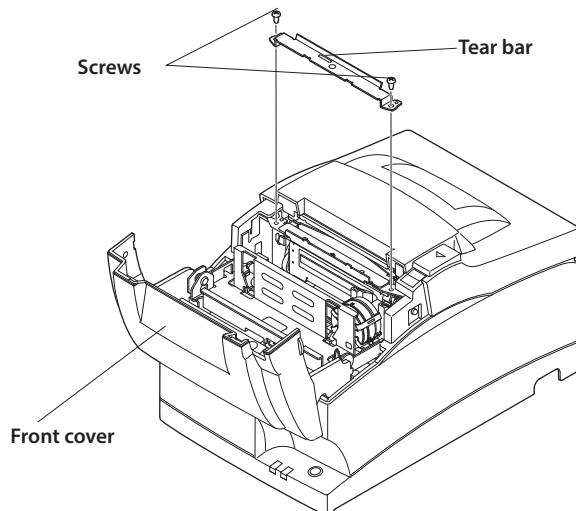

- (6) After you have opened the printer cover, remove the four screws to remove the printer cover and reveal the cutter.

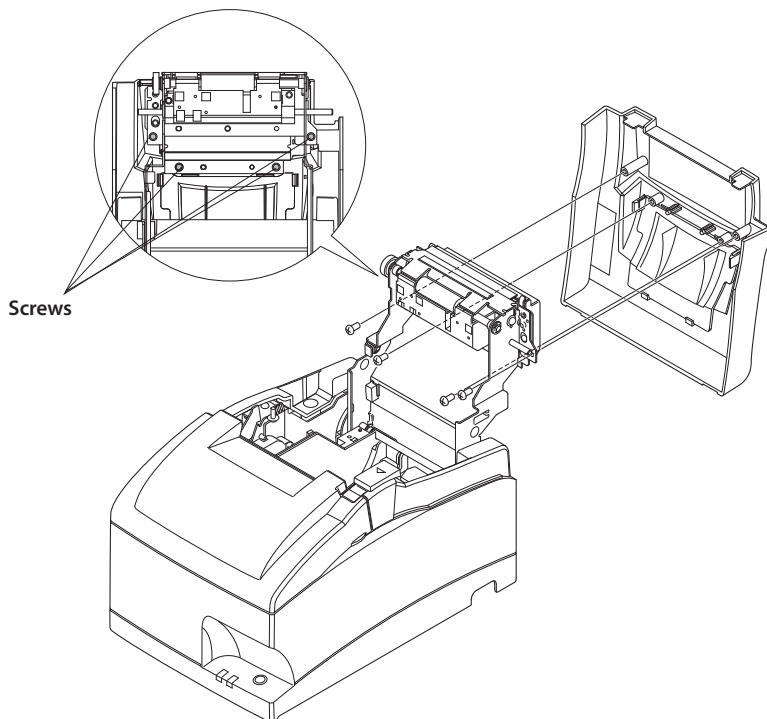

- (7) If the cutter is locked, insert a Phillips screwdriver into the Phillips screw hole on the side of the cutter, and turn it in the direction of the arrow shown below, in order to return the cutter to its normal position.
- (8) Reinstall the printer cover by tightening its screws.

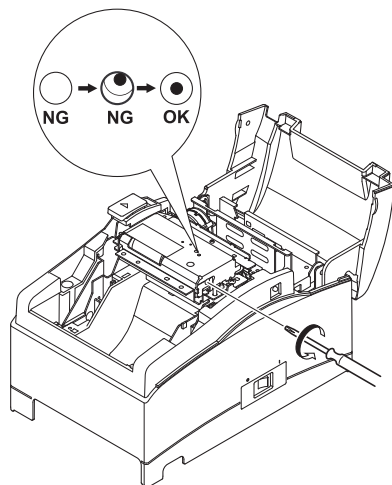

- (9) Reinstall the tear bar by tightening its screws.

English:	Hereby, STAR MICRONICS CO.,LTD. declares that this Wireless Device is in compliance with the essential requirements and other relevant provisions of Directive 1999/5/EC.	Eesti: [Estonian]	Käesolevaga kinnitab STAR MICRONICS CO.,LTD. seadme Wireless Device vastavust direktiivi 1999/5/EÜ põhinõuetele ja nimetatud direktiivist tulenevatele teistele asjakohastele sä tetele.
Deutsch: [German]	Hiermit erklärt STAR MICRONICS CO.,LTD., dass sich das Gerät Wireless Device in Übereinstimmung mit den grundlegenden Anforderungen und den übrigen einschlägigen Bestimmungen der Richtlinie 1999/5/EG befindet.	Ελληνική: [Greek]	ΠΡΟΕΙΔΟΠΟΙΗΣΗ: ΜΕ ΤΗΝ ΠΑΡΟΥΣΑ STAR MICRONICS CO.,LTD. ΔΗΛΩΝΕΙ ΟΤΙ Wireless Device ΣΥΜΜΟΡΦΩΝΕΤΑΙ ΠΡΟΣ ΤΙΣ ΟΥΣΙΩΔΕΙΣ ΑΠΑΙΤΗΣΕΙΣ ΚΑΙ ΤΙΣ ΛΟΙΠΕΣ ΣΧΕΤΙΚΕΣ ΔΙΑΤΑΞΕΙΣ Τ ΗΣ ΟΔΗΓΙΑΣ 1999/5/ΕΚ.
Svenska: [Swedish]	Härmed intygar STAR MICRONICS CO.,LTD. att denna Wireless Device står i överensstämmelse med de väsentliga egenskapskrav och övriga relevanta bestämmelser som framgår av direktiv 1999/5/EG.	Slovensky: [Slovak]	STAR MICRONICS CO.,LTD. týmto vyhlasuje, že Wireless Device spĺňa základné požiadavky a všetky príslušné ustanovenia Smernice 1999/5/ES.
Español: [Spanish]	Por medio de la presente STAR MICRONICS CO.,LTD. declara que el Wireless Device cumple con los requisitos esenciales y cualesquiera otras disposiciones aplicables o exigibles de la Directiva 1999/5/CE.	Slovensko: [Slovenian]	STAR MICRONICS CO.,LTD. izjavlja, da je ta Wireless Device v skladu z bistvenimi zahtevami in ostalimi relevantnimi določili direktive 1999/5/ES.
Português: [Portuguese]	STAR MICRONICS CO.,LTD. declara que este Wireless Device está conforme com os requisitos essenciais e outras disposições da Directiva 1999/5/CE.	Česky: [Czech]	STAR MICRONICS CO.,LTD. tímto prohlašuje, že tento Wireless Device je ve shodě se základními požadavky a dalšími příslušnými ustanoveními směrnice 1999/5/ES.
Français: [French]	Par la présente STAR MICRONICS CO.,LTD. déclare que l'appareil Wireless Device est conforme aux exigences essentielles et aux autres dispositions pertinentes de la directive 1999/5/CE.	Magyar: [Hungarian]	Alulírott, STAR MICRONICS CO.,LTD. nyilatkozom, hogy a Wireless Device megfelel a vonatkozó alapvető követelményeknek és az 1999/5/EC irányelv egyéb előírásainak.
Suomi: [Finnish]	STAR MICRONICS CO.,LTD. vakuuttaa täten että Wireless Device tyyppinen laite on direktiivin 1999/5/EY oleellisten vaatimusten ja sitä koskevien direktiivin muiden ehtojen mukainen.	Български: [Bulgarian]	това Безжично устройство е в съответствие със задължителните изисквания и другите приложими разпоредби на Директива 1999/5/EC.
Italiano: [Italian]	Con la presente STAR MICRONICS CO.,LTD. dichiara che questo Wireless Device è conforme ai requisiti essenziali ed alle altre disposizioni pertinenti stabilite dalla direttiva 1999/5/CE.	Polski: [Polish]	Niniejszym STAR MICRONICS CO.,LTD. oświadcza, że Wireless Device jest zgodny z zasadniczymi wymogami oraz pozostałymi stosownymi postanowieniami Dyrektywy 1999/5/EC.
Dansk: [Danish]	Undertegnede STAR MICRONICS CO.,LTD. erklærer herved, at følgende udstyr Wireless Device overholder de væsentlige krav og øvrige relevante krav i direktiv 1999/5/EF.	Malta: [Maltese]	Hawnhekk, STAR MICRONICS CO.,LTD., jiddikjara li dan Wireless Device jikkonforma mal-ħtiġijiet essenzjali u ma provvedimenti oħrajn relevanti li hemm fid-Dirrettiva 1999/5/EC.
Nederlands: [Dutch]	Hierbij verklaart STAR MICRONICS CO.,LTD. dat het toestel Wireless Device in overeenstemming is met de essentiële eisen en de andere relevante bepalingen van richtlijn 1999/5/EG.	Latviski: [Latvian]	Ar šo STAR MICRONICS CO.,LTD. deklarē, ka Wireless Device atbilst Direktīvas 1999/5/EK būtiskajām prasībām un citiem ar to saistītajiem noteikumiem.
		Lietuvių : [Lithuanian]	Šiuo STAR MICRONICS CO.,LTD. deklaruoja, kad šis Wireless Device atitinka esminius reikalavimus ir kitas 1999/5/EB Direktyvos nuostatas.

Declaration of Conformity

Application of Council Directive(s)

1999/5/EC of 9 Mar 1999
2004/108/EC of 15 Dec 2004
2006/95/EC of 12 Dec 2006
2011/65/EU of 8 Jun 2011

Standard(s) to which Conformity is Declared

RADIO : **EN 300 328 V1.7.1**
EN 62479 : 2010
EMISSION : **EN 301 489-1 V1.9.2**
EN 301 489-17 V2.2.1
EN 55022 : 2010 Class B
EN 61000-3-2 : 2006 / +A1 +A2 : 2009
EN 61000-3-3 : 2008
IMMUNITY : **EN 55024 : 2010**
SAFETY : **EN 60950-1 : 2006 / +A12 : 2011**
EN 62311 : 2008
ENVIRONMENT: **EN 50581: 2012**

Manufacturer's Name **Star Micronics Co.,Ltd.**
Manufacturer's Address **20-10 Nakayoshida, Suruga-ku, Shizuoka-shi,
Shizuoka 422-8654 Japan**

Importer's Name **Star Micronics Europe Ltd.**
Importer's Address **Star House, Peregrine Business Park, Gomm Road,
High Wycombe, Bucks. HP13 7DL, U.K.**

Type of Equipment **Dot Matrix Printer**
Model Name **SP700 , SP700R , 4679-GCS (Interface : IFBD-HB04)**
Ref. Radio Report No. **F092137E3**
Ref. EMC Report No. **F092137E4 , 90-017-EMC , 4816908**
Ref. Safety Cert. No. **JPJQA-10178**
Ref. Environ. Report No. **SP700-RoHS-01**

I , the undersigned , hereby declare that the equipment specified above conforms to the above Directive(s) and Standard(s).

Place High Wycombe - U.K. *D. Pearce* (Signature)

Date Jun. 11 , 2014 David Pearce (Full Name)

Year of 1st CE mark '06 Technical Director (Position)



URL: <http://www.star-m.jp/eng>